

Selection Assessments

All applicants must be available for assessment within Australia. Travel to and from any assessment location is at the applicant's expense.

The assessments may change at any time before or during the selection process, and applicants will be notified of any changes.

Applicants who are deemed unsuccessful at any stage of the selection process will be excluded from further assessments and will be formally advised in writing. They will be welcome to re-apply 6 months after receiving formal notification of their unsuccessful application.

Initial assessment of applications

All applications will be assessed, taking into consideration a number of factors including:

- Eligibility - citizenship/permanent residency status
- Lodgement of the required forms/requested information
- Written response to the two job related application questions.

Once applications have been assessed, applicants will be advised whether they have been successful in progressing to the next stage of the selection process.

Applicants who are deemed unsuccessful at this stage will be excluded from further assessments and selection processes and will be formally advised in writing. They will be welcome to re-apply 6 months after receiving formal notification of their unsuccessful application.

Employment Profile Assessment

The Employment Profile Assessment consists of a number of written tests and questionnaires that have been selected to assess some of the skills, abilities and characteristics required to work successfully in a custodial environment as a Prison Officer with the WA Department of Corrective Services. The Employment Profile Assessment can take up to 4 hours to complete, and consists of two parts:

1. **Ability and aptitude tests:** A series of timed tests assessing reading, writing, verbal and abstract reasoning ability.
2. **Personality questionnaires:** A number of questionnaires that are designed to provide information about how one applicant's personality may be similar to and different from that of other applicants.

Each applicants' aptitude test scores are compared, and only the most competitive are progressed to the next stage. An applicant's responses to the personality questionnaires will be taken into consideration later in the selection process if applicable.

Applicants are deemed unsuccessful if their aptitude test scores do not meet the requirements. Unsuccessful applicants will be excluded from further assessment and will be formally advised in writing.

GADFREY MARYO (10138783)

MAN 5251
ASSIGNMENT 1
TESTS USED IN SELECTION
PRISON OFFICER

Note: Employment Profile Assessment results remain valid for 12 months, and therefore an applicant may not complete the assessment more than once in a 12-month period. An applicant's results will be used for any subsequent application they make during the 12 months from the date of their last Employment Profile Assessment.

Selection Panel Interview

A selection panel interview assesses an applicant's level of skills, abilities and knowledge against the work-related criteria listed in the Job Description Form. A selection panel consisting of two or three panel members will ask a series of questions relevant to the role, based on these criteria. For the purpose of this assessment, the selection panel may also take into consideration information obtained through an applicant's resume, referee reports, and the Employment Profile Assessment results.

Selection panel interviews may take up to one hour. Applicants who are deemed unsuccessful at this stage will be excluded from further assessment and selection processes and will be formally advised in writing.

Note: Unsuccessful applicants are welcome to re-apply 6 months after receiving formal notification of the outcome of their application.

Preparing for the Selection Panel Interview

All applicants should take into account the following information to prepare for the interview:

- Be familiar with the work-related criteria outlined in the Job Description Form
- Consider the work-related criteria and think of specific examples of situations where you have applied the relevant skills and abilities
- Focus on the duties of the position and how they should be carried out, considering problems that might be encountered and how they would be resolved. It is also important to consider outcomes and results achieved
- Be punctual and appropriately attired - neat and professional
- Take time to answer each question and present answers clearly and concisely
- Use the interview to ask any questions that you may have in relation to the position.

Applicants attending the interview will be asked to bring several completed department forms with them. This information will be advised in writing/provided when confirming the interview time.

Psychological Interview

Some applicants may be requested to take part in further assessments through an interview with a Psychologist. If required, the interview will be completed in person or by telephone depending on your location, and can take up to one hour. If invited for an interview with a Psychologist, it is recommended that applicants adhere to normal interview protocol including appropriate attire.

Recommendations from the interviewing Psychologist are taken into consideration by the Decision Panel in determining an applicant's suitability for employment, which occurs **at the end of the selection process** (see section on Decision Panel).

Medical Assessment

Applicants who have successfully completed prior stages of the assessment and selection processes will be required to undergo a medical assessment conducted by our external medical practitioners. Medical assessments are used to ascertain an applicant's ability to complete the Prison Officer training course and their ability to perform the duties of a Prison Officer.

The Department covers the cost of the initial medical assessment. Any subsequent follow-up medical advice, if required, is at the applicant's cost. Applicants who are deemed unsuccessful at this stage will be excluded from further assessment and selection processes and will be formally advised in writing. Depending on the reasons for exclusion, applicants may not be eligible to be reconsidered if they reapply.

Note: Unsuccessful applicants at the medical stage are welcome to re-apply 6 months after receiving formal notification of the outcome of their application.

Fitness Assessment

Applicants who have successfully completed prior stages of the assessment and selection processes will be required to participate in a fitness assessment. Prison Officers perform a range of duties, which may involve physical exertion such as running, bending, lifting heavy objects, being able to navigate obstacles and controlling non-compliant inmates.

The ability to perform these tasks in a safe and capable manner must be assessed prior to employment. This information below details the minimum fitness standards that must be demonstrated and maintained by all Prison Officer applicants. Meeting and maintaining these standards helps to prevent injury while training and on the job.

The standards of fitness required for males and females are different, irrespective of age. These standards must be met or applicants will be excluded from further assessment and selection processes and will be formally advised in writing.

The fitness assessment consists of the following:

- 20 metre shuttle run (beep test)
- Push ups test
- Zigzag agility test.

It is recommended that applicants prepare for the fitness assessment well in advance prior to the assessment. For further information about fitness requirements, please refer to the information below, **Prison Officer Fitness Requirements**, which includes a suggested fitness program to assist applicants in preparing for the assessment.

If an applicant is unsuccessful in meeting the requirements of their first fitness assessment they may be offered one of the following:

- The ability to participate in a second fitness assessment session (at the department's discretion) subject to time and resource constraints, or
- If the fitness assessment is the only assessment stage not successfully competed, applicants may be given up to three (3) months from the date of lodgment of their application to meet the fitness requirements. Applicants who do not meet the fitness assessment requirements will be excluded from the selection process.

Note: Unsuccessful applicants at the medical stage are welcome to re-apply 6 months after receiving formal notification of the outcome of their application.

Fitness Standards

The minimum standards are:

	Shuttle Run	Agility Test	Push-ups
Male	Level 6	13 seconds	14
Female	Level 3.6	14 seconds	7 (Method 1) or 14 (Method 2) – See overleaf

Warm Up Preparation

On the day of the test, you will be allowed 10 mins warm up time. We suggest quad stretches, calf stretches, shoulder reflexes and arm warm ups.

20 Metre Shuttle Run Test (Beep Test)

This test is designed to measure your aerobic capacity to run a distance with stops at regular intervals.

It requires you to run 20 metres from one line to another in accordance with beeps on a CD. This tests your overall aerobic fitness. The beeps start off slowly, allowing 9 seconds to run 20 metres (a fast pace walk) and then decreases by .02 of a second. Each stage has 7-9 steps, which will decrease in time.

You must place your foot on or over the line before the beep sounds, this continues over and over again. You will have two chances in the test - if the beep sounds before you touch the line but make it to the next line on time, you are safe.

If you do not touch the line on the first time before the beep and fail to touch the line next time before the beep, it is considered to be two chances.

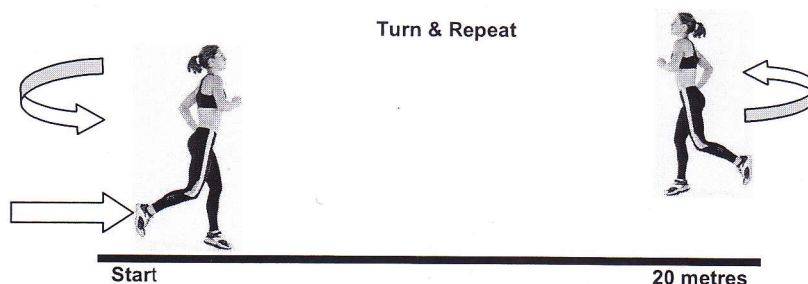

Zigzag Agility Test

This test is to see if you move well in confined spaces and around objects. There are four cones set up in a rectangular shape. The idea is to run to each cone, within a time limit, in a figure eight pattern, whilst touching the cones as you pass them. This includes *kneeling* and *lying down on your back* at set points.

The set up of this is as follows:

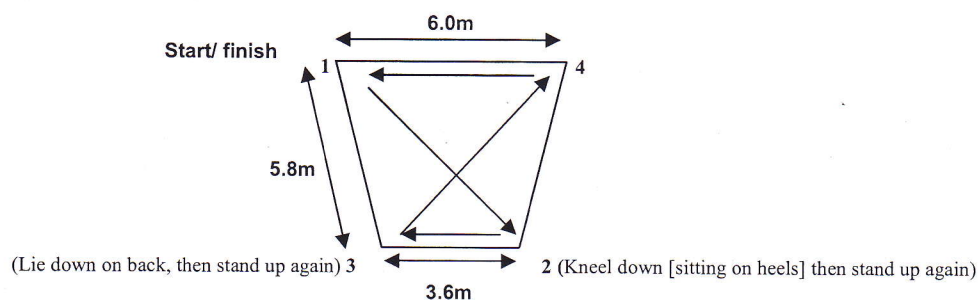

Push Ups Test

Push-ups provide an indication of upper body strength and endurance, as well as stabilising abdominal strength. The cadence (speed of the push-up) is one push-up per two seconds.

Males

Start the push up position with the toes on the ground, feet together, arms shoulder-width apart with palms flat. The back should be straight and the head looking forward or down and arms fully extended, the 'up' position.

- From the 'up' position the arms bend to a 90 degree angle from the shoulder to elbow. The body should remain generally in a straight line and parallel to the ground. This is the 'down' position.
- Keeping the body generally in a straight line, the arms are then extended so that the body returns to the 'up' position.
- Returning to the 'up' position constitutes one repetition.
- The push ups must be conducted in a continuous movement to the designated standard.

Females

Method 1: Same as for males (see above)

Method 2: Start the push up position with the knees on the ground, arms shoulder-width apart with palms flat. The back should be straight and the head looking forward or down and arms fully extended, the 'up' position.

- From the 'up' position the arms bend to a 90 degree angle from the shoulder to elbow. The body should remain generally in a straight line. This is the 'down' position.
- Keeping the body generally in a straight line, the arms are then extended so that the body returns to the 'up' position.
- Returning to the 'up' position constitutes one repetition.
- The push ups must be conducted in a continuous movement to the designated standard.

Training for the Fitness Assessment

Below is a guide to improve your fitness in 4 weeks. You should start training as soon as possible. Ensure that you stretch, warm-up and cool down prior to such exercise.

Note: Prior to beginning training, it is your responsibility to ensure that you do not have any injuries that may be aggravated by exercise. See your doctor if you are uncertain.

	Monday	Tuesday	Wednesday	Thursday	Friday	Saturday	Sunday
Week 1	Am: 40 min brisk walk; Pm: Push-ups & sit-ups 10x, rest; 8x, rest; 6x, rest	Am: Light run 1.5 km Pm: Ride/walk for 30-40 mins	Push-ups & sit-ups 10x, rest; 8x, rest; 6x, rest.	Rest	Am: 40 min brisk walk	Push-ups & sit-ups 10x, rest; 8x, rest; 6x, rest.	Rest
Week 2	Am: 40 min brisk walk; Pm: run 1.8 km	Am: Push-ups & sit-ups 12x, rest; 10x, rest; 8x, rest Pm: 40 min brisk walk	Rest	Am: Ride/walk for 40 mins Pm: Push-ups & sit-ups 12x, rest; 10x, rest; 8x, rest	Am: run 1.8 km Pm: Push-ups & sit-ups 12x, rest; 10x, rest; 8x, rest	Rest	Am: walk for 30-40 mins;
Week 3	Am: Run 2km Pm: Push-ups & sit-ups 14x, rest; 12x, rest; 10x, rest	Am: Walk for 40-50 mins;	Am: run 2 km Pm: Push-ups & sit-ups 14x, rest; 12x, rest; 10x, rest	Am: 40 min brisk walk;	Rest	Am: run 2 km Pm: Push-ups & sit-ups 14x, rest; 12x, rest; 10x, rest	Am: 40 min walk Pm: Push-ups & sit-ups 14x, rest; 12x, rest; 10x, rest
Week 4	Am: 55 min brisk walk; Pm: Push-ups & sit-ups 16x, rest; 14x, rest; 12x, rest	Am: run 2.3 km Pm: 55 min brisk walk;	Rest	Am: Push-ups & sit-ups 16x, rest; 14x, rest; 12x, rest	Am: 55 min brisk walk Pm: run 2.3 km;	Rest	Am: Push-ups & sit-ups 16x, rest; 14x, rest; 12x, rest

Criminal Records Screening and Integrity Assessment

Applicants who are invited to interview will be required to undergo **criminal records screening** and an **integrity assessment**. A previous criminal conviction or pending charge will not necessarily preclude a person from being employed with the Department.

Applicants must successfully meet these requirements to be eligible for appointment to the Prison Officer (Entry Level) Appointment pool. Only an applicant who is invited to interview will be required to undertake these checks and will be provided the forms to complete at this time. Further information will be provided at the selection panel Interview.

GODFREY MAYO (10138783)

5